

Jan 24



## **RF Amplifier**

**Including: Basic Deflector Alignment**

**D1384-aQ110-x**

**D1384-aQ120-x**

**D1384-aQ140-x**

**D1384-aQ170-x**

## **Instruction Manual**

**RFA0110-4 / RFA0120-4 / RFA0140-4 / RFA0170-4 -x Series**

Models -

RFA0110-4-20 : 90 -130MHz, dual amplifier module, 20W per output

RFA0120-4-15 : 100-140MHz, dual amplifier module, 15W per output

RFA0120-4-25 : 100-140MHz, dual amplifier module, 25W per output

RFA0140-4-12 : 110-160MHz, dual amplifier module, 12W per output

RFA0170-4-10 : 130-210MHz, dual amplifier module, 10W per output

Options -x:

ISOMET CORP, 10342 Battleview Parkway, Manassas, VA 20109, USA.

Tel: (703) 321 8301, Fax: (703) 321 8546, e-mail: [isomet@isomet.com](mailto:isomet@isomet.com)

[www.ISOMET.com](http://www.ISOMET.com)

ISOMET (UK) Ltd, 18 Llantarnam Park, Cwmbran, Torfaen, NP44 3AX, UK.

Tel: +44 1633-872721, Fax: +44 1633 874678, e-mail: [sales-uk@isomet.com](mailto:sales-uk@isomet.com)



## 1. GENERAL

The RFA01n0-4-x series power amplifiers, figure 1, contain four independent fixed gain broadband RF amplifiers specifically designed to operate with the Isomet iMS4 synthesizer driving acousto-optic dual axis deflectors such as the D1384-XY-aQ1n0 series. Each channel of these amplifiers requires a low level RF signal from a suitable frequency source such as the Isomet iMS4-P (or -L) frequency synthesizer. Figure 2 shows a functional block diagram of the driver.

The rise and fall response time for the amplifier is approx' 25nsec.

This amplifier is designed to operate at full rated power into a 50Ω load with 100% duty cycle.

Trace 1 = RF output

Trace 2 = Sync signal

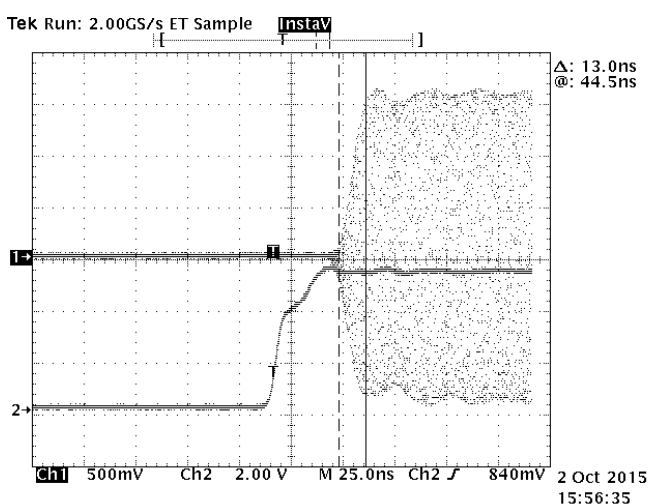

**Water cooling is mandatory. The heatsink temperature must not exceed 70°C.**

**SERIOUS DAMAGE TO THE AMPLIFIER MAY RESULT IF THE TEMPERATURE EXCEEDS 70°C.  
SERIOUS DAMAGE TO THE AMPLIFIER MAY ALSO RESULT IF THE RF OUTPUT CONNECTOR IS OPERATED OPEN-CIRCUITED OR SHORT-CIRCUITED.**

A low impedance d-c power supply is required. The operating voltage is +24V or +28Vdc at a current drain of approximately 12A (model dependent- see specific data sheet). The external power source should be regulated to ± 2% and the power supply ripple voltage should be less than 200mV for best results.

Higher RF output power is achieved at 28Vdc.

## 2.1 LED INDICATOR

The front panel tri-colour LED indicates the operating state.

### YELLOW

The middle LED will illuminate YELLOW when 24Vdc supply is applied.

**Normal condition is ON**

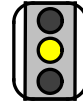

### GREEN

The top LED will illuminate GREEN when Amplifier and AO thermal interlocks\* are valid. **Normal condition is ON**



### RED

The lower LED will illuminate RED when the following signals are all true:

- 1) RF DC power is applied and
- 2) Amplifier and AO thermal interlocks are valid and
- 3) Gate signal is valid (via J9 of the iMS4 plus Software command )

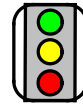

**Normal condition is all ON**

### **\* Thermal Interlocks**

The AOM and Driver are fitted with thermostatic switches which will switch open circuit if a predetermined temperature is exceeded. These thermal interlocks will reset once the AO device and / or RF driver are cooled below this temperature.

- The driver thermal switch over-temperature threshold is 50deg C
- The AOD thermal switch over-temperature threshold is 40deg C \*

The hysteresis of the thermal switches is 7-10deg C.

**Once in a fault state the coolant temperature will need to be reduced to reset the thermal switches.**

(\* AO model dependent)



### 3.0 INSTALLATION AND ADJUSTMENT

Please refer to the Synthesizer manual for frequency, phase and amplitude control of the input signals.

3.1 Connect cooling water at a flow of more than 1 litres/minute at < 25 deg.C to both the RF amplifier and AO device. Due to the RF power dissipated in the AO modulator, it is paramount that the device is operated only when water cooling is circulating. For optimum AO performance, ensure the flow rate is 2 litres /minute at < 20 deg.C.

3.2 With no d-c power applied, connect the + 24V (or +28V) DC in to the screw terminal.  
DO NOT APPLY POWER.

3.3 Connect the RF output BNC jacks to the acousto-optic deflector (or a 50Ω RF load, if to measure the modulator RF output power).

Connection order depends on the orientation as shown on page 12.

Relative phase delay depends on the input source.

3.3.1 Connect the RF input SMA jacks to the external frequency source outputs (1mW max, 50Ω, each input).

3.3.2 Connect the Interlock of the acousto-optic device to the mating connector of the RF driver (Binder 3pin snap connector).

The interlock connection becomes open circuit disabling the RF output, if the temperature of the modulator exceeds 40°C or the internal driver temperature exceeds 50°C. The LED indicator illuminates when the Interlocks are closed and the RF is enabled (see Section 2).

3.3.3 Connect the Control cable from J5 of the iMS4 to the 15-way high density D-Type input of the RF amp. NOTE: If not using the iMS4, a GATE input is required (see Connection Summary page 8)



- 3.4 Adjustment of the RF output power is best done with amplifier connected to the acousto-optic modulator.
- 3.5 **The optimum RF power level required for the modulator to produce maximum first order intensity will be different at various laser wavelengths. Applying RF power in excess of this optimum level will cause a decrease in first order intensity (a false indication of insufficient RF power ) and makes accurate Bragg alignment difficult. It is therefore recommended that initial alignment be performed at a low RF power level.**
- 3.6 Set the input power level to give approximately 6W per output.
- 3.7 Apply DC power to the amplifier.
- 3.8 Apply a constant RF input to the input SMA connector of the RFA01x0-4

Input the laser beam toward the centre of either aperture of the AO device. For Quartz AO devices ensure the polarization is vertical with respect to the diffraction axis and the beam height does not exceed the active aperture height of the AOM/AOD.

Start with the laser beam normal to the input optical face of the AOD and very slowly rotate the AOD (see page 12 for configurations.)

- 3.9 Observe the diffracted first-order output from the acousto-optic modulator and the undeflected zeroth order beam. Adjust the Bragg angle (rotate the modulator) to maximise first order beam intensity.
- 3.10 After Bragg angle has been optimized, slowly increase the RF input power until maximum first order intensity is obtained. e.g. this should occur at < 11W per output for the D1384-aQ110-7 at 532nm.

3.11 To equalise deflection efficiency at the extremes of the scan, alternate between the minimum and maximum desired frequencies and adjust Bragg angle to give the same efficiency for both. **The correct phase offset at each frequency must be applied.** (Note: the photo detector or light power meter will require repositioning for the two angles.) Sweeping the freq' input should result in a continuous deflected line output. If significant peaks and troughs are noted across the sweep, it is probable that the phase shift between the RF channels is incorrect for the Bragg orientation of the AO deflector.

The lead lengths between the two outputs of the RF driver and the beam steered deflector should be equal unless otherwise instructed. Unequal lengths of more than a 1cm would introduce a phase error.

3.12 Repeat for the orthogonal axis

Typical swept frequency response at 532nm

Example of a single axis scan,  
532nm, 40MHz sweep

*Trace 4: = 100% efficiency level*  
*Trace 2: = 0% efficiency level*  
*(and sync pulse)*  
*Trace 1: = detector output*

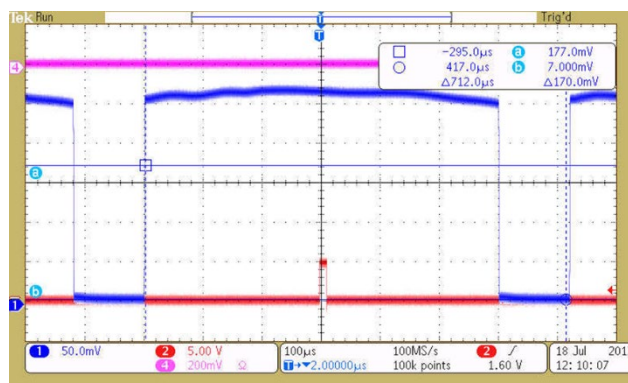

First order diffraction efficiency vs RF drive frequency



#### 4. MAINTENANCE

##### 4.1 Cleaning

It is of utmost importance that the optical apertures of the deflector optical head be kept clean and free of contamination. When the device is not in use, the apertures may be protected by a covering of masking tape. When in use, frequently clean the apertures with a pressurized jet of filtered, dry air.

It will probably be necessary in time to wipe the coated window surfaces of atmospherically deposited films. Although the coatings are hard and durable, care must be taken to avoid gouging of the surface and leaving residues. It is suggested that the coatings be wiped with a soft ball of brushed (short fibres removed) cotton, slightly moistened with clean alcohol. Before the alcohol has had time to dry on the surface, wipe again with dry cotton in a smooth, continuous stroke. Examine the surface for residue and, if necessary, repeat the cleaning.

##### 4.2 Troubleshooting

No troubleshooting procedures are proposed other than a check of alignment and operating procedure. If difficulties arise, take note of the symptoms and contact the manufacturer.

##### 4.3 Repairs

In the event of deflector malfunction, discontinue operation and immediately contact the manufacturer or his representative. Due to the high sensitive of tuning procedures and the possible damage which may result, no user repairs are allowed. Evidence that an attempt has been made to open the optical head will void the manufacturer's warranty.

**RFA 01n0-4 Standard Version**

**Connection Summary**

1.0 'D' Type Control Connection  
 Normal connection is to J5 of iMS4

<u>Signal</u>	<u>Type</u>	<u>Pin out connection</u>
Digital Gate Internal pull up to 5Vdc	Input	Signal pin 9 Return pin 4
Closed or logic LOW (0.0v<V<0.8v)	= ON	
Open or 5V logic High (2.0v<V<5.0v)	= OFF	

**The above ONLY applies if RFA originally supplied without an iMS4  
 DO NOT make connection to other pins**

2.0 Coaxial SMA (4x) Inputs

Low level RF Input

Frequency range	50MHz Minimum, 210MHz Maximum
Power level	0dBm (1mW) Typical  3dBm (2mW) Maximum

3.0 Interlock connection

AOM Thermal Interlock Plug  
 (OK = connected contacts  
 1-2)

RF Driver INT Plug  
 (OK = connected  
 contacts 1-2)



The interlock signal must be connected. Contacts closed for normal operation.

4.0 Mounting Holes

4 x M5



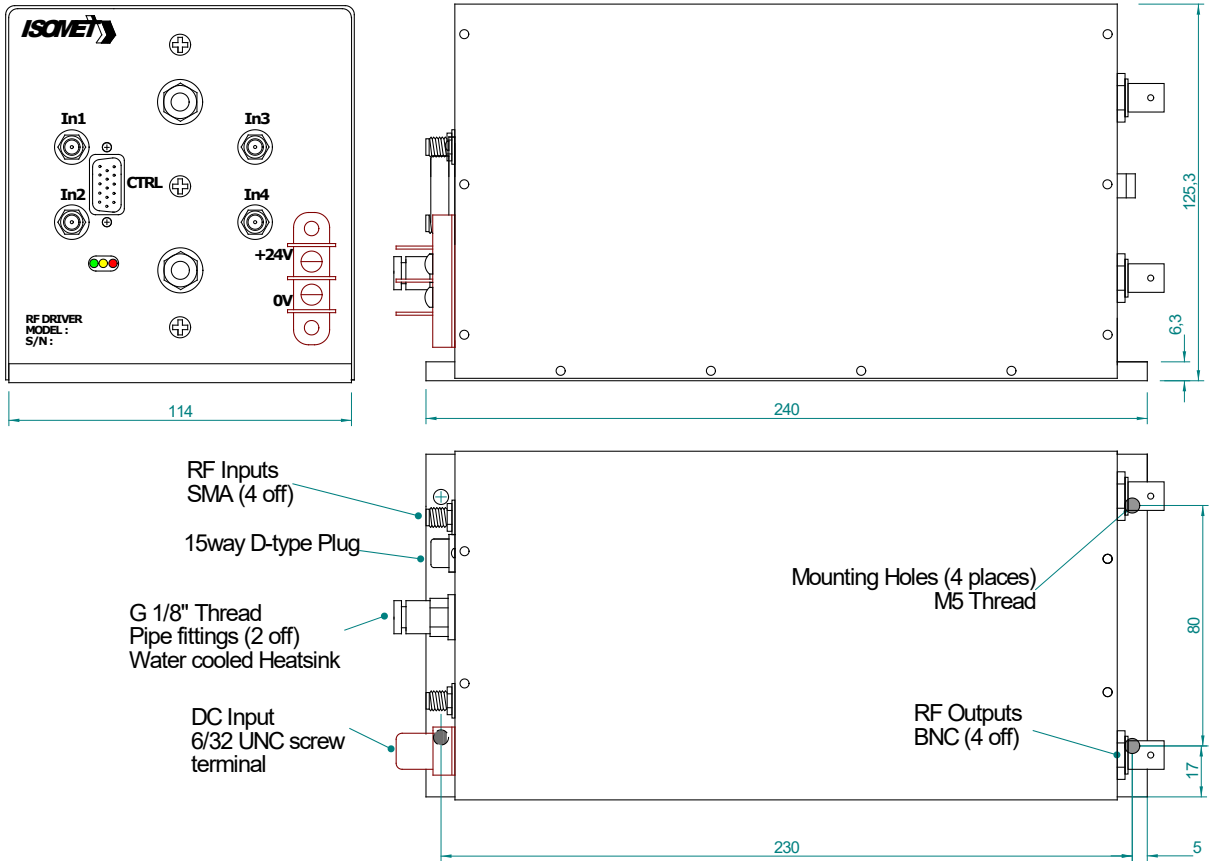

Figure 1: Driver Installation

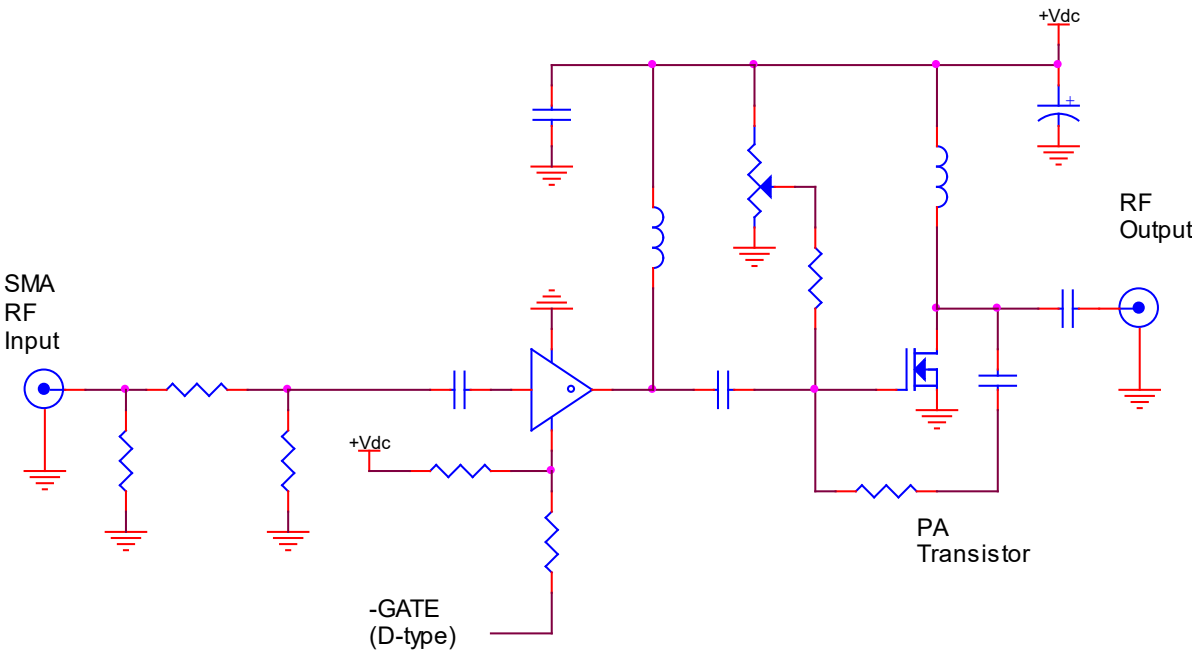

Figure 2: Driver Block Diagram. Per Channel

XY Scan, -1, -1 orientation

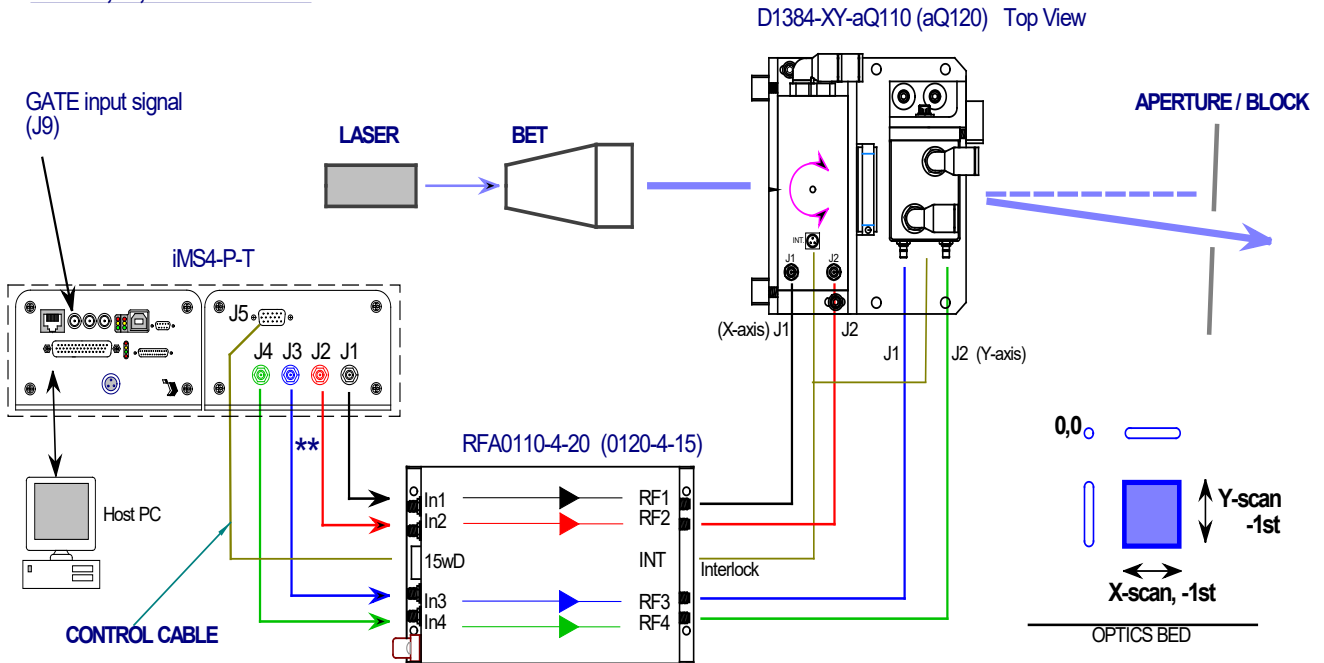

Figure 4: Typical Connection Configuration

Diagram shows beam alignment for -1, -1 Bragg.

See connection options below for alternate Bragg.

Connection options

Connection options for Beam Steered AO Deflectors

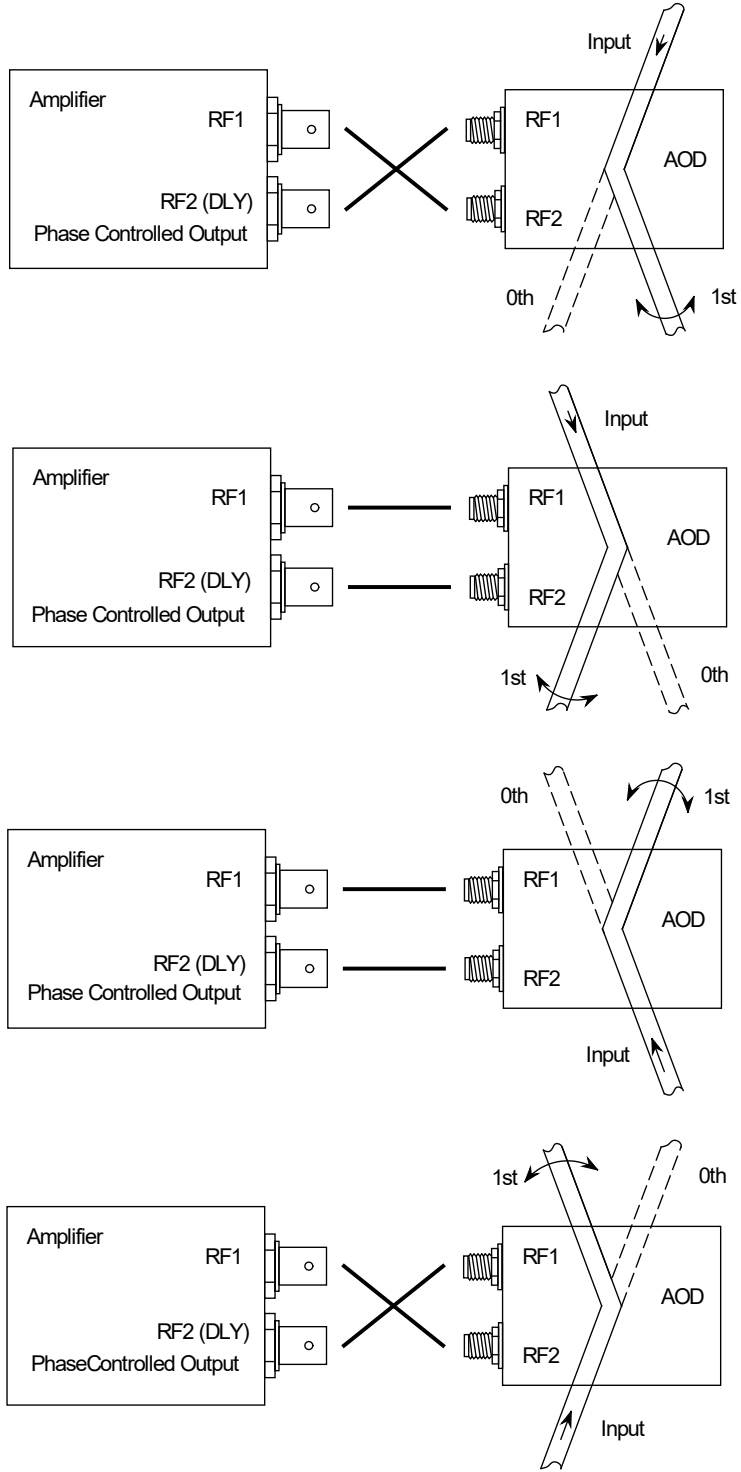

Correct orientation as viewed from top of AOD  
 (Connector type and identification may differ)

**Schematic of a single electrode acousto optic deflector and tunable driver**

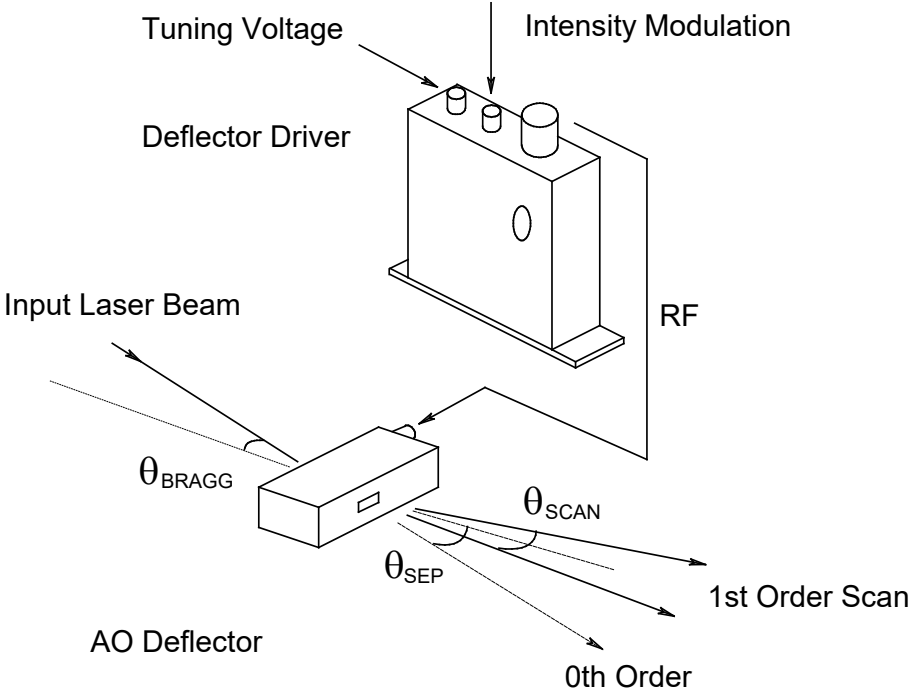

The input Bragg angle, relative to a normal to the optical surface and in the plane of deflection is :

$$\theta_{BRAGG} = \frac{\lambda \cdot fc}{2 \cdot v}$$

The separation angle between the zeroth order and mid scan point of the first order is :

$$\theta_{SEP} = \frac{\lambda \cdot fc}{v}$$

The first order scan angle is :

$$\theta_{SCAN} = \frac{\lambda \cdot \delta f}{v}$$

where:  $\lambda$  = wavelength  
 $fc$  = centre frequency e.g. 110MHz / 120MHz / 140MHz / 170MHz  
 $v$  = acoustic velocity of interaction material = 5.7mm/usec (a-Quartz)

$d = 1/e^2$  beam diameter

Figure 5. Deflection System